

# Analog Bottom Mount MEMS Microphone

## IRS-3526-AB-3868

With the IR Sensors advanced silicon microphones incorporated into your products, your customers will enjoy a better experience. Their sound quality will be improved thanks to higher signal to noise ratio (SNR), high output sensitivity and low cut-off frequency. Their battery life will be extended thanks to lower power consumption. Product reliability will improve because IR microphones are intrinsically dustproof and waterproof. As an end user product manufacturer, you will benefit from the small package size and single output. IR microphones are drop-in replacements for your current choice and offer tape & reel or tube packaging. Our multiple global foundry partners mitigate delivery risks and supply chain delays. It's time to try the new generation of MEMS microphones.

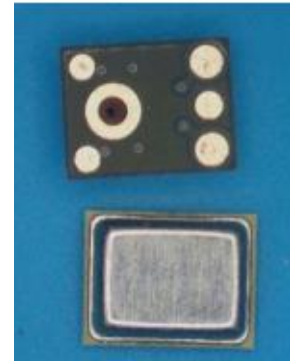

With the IR Sensors advanced silicon microphones incorporated into your products, your customers will enjoy a better experience. Their sound quality will be improved thanks to higher signal to noise ratio (SNR), high output sensitivity and low cut-off frequency. Their battery life will be extended thanks to lower power consumption. Product reliability will improve because IR microphones are intrinsically dustproof and waterproof. As an end user product manufacturer, you will benefit from the small package size and single output. IR microphones are drop-in replacements for your current choice and offer tape & reel or tube packaging. Our multiple global foundry partners mitigate delivery risks and supply chain delays. It's time to try the new generation of MEMS microphones.

### Description

The IR-3526-AB-3868 Product series of MEMS capacitive silicon microphones are patented, advanced design microphones, developed and manufactured to cater to various customer applications and future requirements. In this design, capacitive sensing technology is taken to the next level in which a single platform technology is able to achieve a wide range of SNR from -60dB to -80dB and beyond to meet the next wave of microphone requirements. Unique patented designs and processes offer world class state of the art microphones for high-volume and high-performance applications. The patented design allows high SNR and smaller die size which allows smaller package meeting the demand for future ever smaller footprints.

### Features

- High SNR > 67dB
- Low Noise
- Omni directional
- Small SMD package
- High sensitivity, -38dB typical
- JEDEC compatible
- Bottom & top mount
- RoHS compatible
- Low frequency roll off by design, 20 Hz, typical
- Intrinsically waterproof and dustproof
- Tape & Reel packaging or tube packaging
- Low current consumption, < 130 uA

### Typical Applications

- Mobile Phones
- Audio devices
- Earphone and Earbud
- Laptop / PC / Tablet
- Automotive
- Remote Sensing
- Door Bell
- Home Automation
- Camera

# Analog Bottom Mount MEMS Microphone

## The Crown Jewel of MEMS microphones

The IR microphone sensor is a novel technology that enables us to produce smaller microphones up to 60% reduction in package volume and up to 60% reduction in power consumption compared to other manufacturers, for same SNR.

IR's innovative two substrates design and fabrication

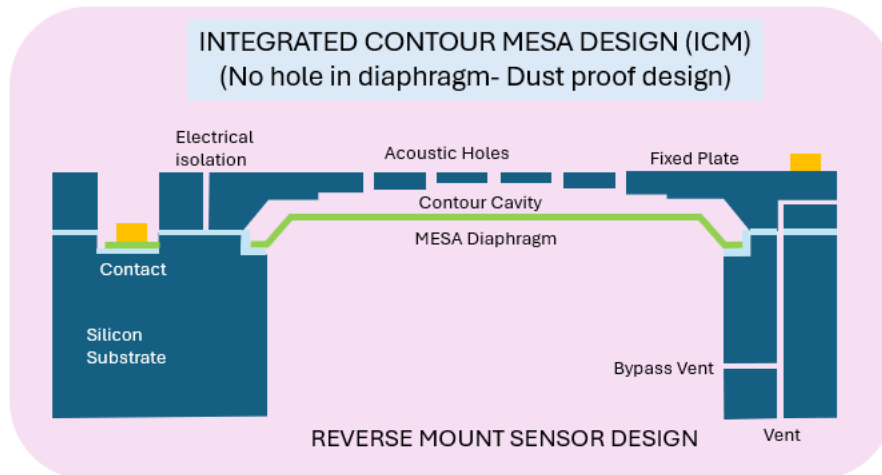

The Unique patented technology consists of multiple unique features including trapezoidal diaphragm design and contour cavity, which provides greater sensitivity and lower acoustic noise that enables to reach SNR of -80dB with single output and smaller footprint.

## Order Information

Product ID	Package	Marking/Order Code
IR3526AB3868	MP-B-3526-68	IR02

# Analog Bottom Mount MEMS Microphone

## PRODUCT KEY PERFORMANCE SPECIFICATIONS

Technical Specification: All data taken at 25±2°C, Relative Humidity 45±5% unless otherwise specified.

### General Ratings Specifications

SPECIFICATION	MINIMUM	TYPICAL	MAXIMUM	UNITS
Operating Temperature	-40	-	+85	°C
Storage Temperature	-40	-	+100	°C
MSL (moisture sensitivity Level)	Class 1			

## Product Key Acoustic Performance Specification

PARAMETER	SYMBOL	TEST CONDITION	VALUES			UNITS
			MIN	TYP	MAX	
Directivity			Omni-directional			
Sensitivity	S	94 dB SPL @ 1kHz	-40	-38	-36	dB V/Pa
Signal to Noise Ratio	SNR	94 dB SPL @ 1kHz, A-weighted		68		dB
Total Harmonic Distortion	THD	94 dB SPL @ 1kHz			0.1	%
Acoustic Over Pressure	AOP	10% THD @ 1kHz		>130		dB SPL
Low Frequency Cut-off	LFCO			20		Hz
High Frequency Flatness		+3dB relative to @ 1KHz		10		kHz

# Analog Bottom Mount MEMS Microphone

## Electrical Key Characteristics and Performance

PARAMETER	SYMBOL	TEST CONDITION	VALUES			UNITS
			MIN	TYP	MAX	
Input / Supply Voltage	V <sub>DD</sub>		1.5	2.5	3.3	V
Input current	I <sub>DD</sub>	V <sub>DD</sub> =1.5V-3.3V	90	115	130	μA
Output impedance	Z <sub>OUT</sub>	94 dB SPL @ 1kHz, Single-ended output	-	-	200	Ohm
Power Supply Rejection	PSR	100mVpp Square wave @217Hz, A-weighted		-103		dBFS
Power Supply Rejection Ratio	PSRR	200mVpp sine wave at 1kHz, V <sub>DD</sub> =1.8V		70		dB
DC output voltage	V <sub>OUT_DC</sub>	V <sub>DD</sub> =1.5V-3.3V, Single ended output		0.85		V
Start-up time	t <sub>start</sub>	Single-ended output		15		mS
Equivalent input noise	EIN	Noise measured with A- weighted filter		3		μV

## TYPICAL FREQUENCY RESPONSE CURVE

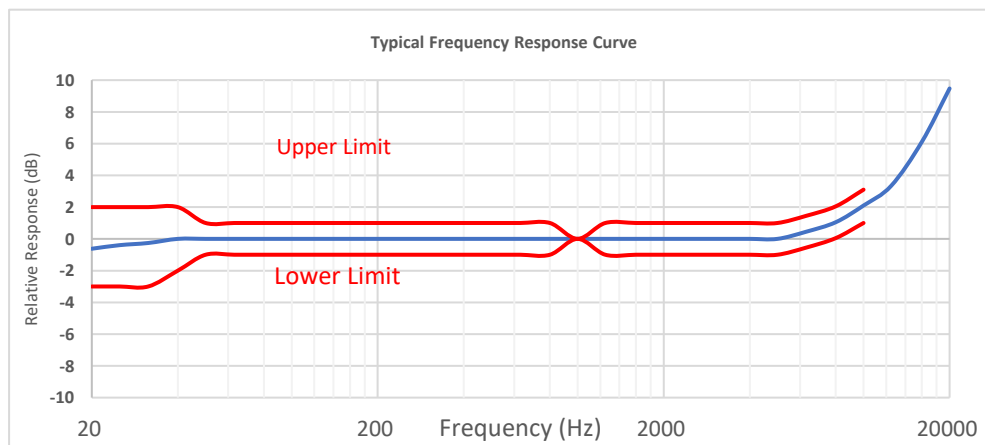

# Analog Bottom Mount MEMS Microphone

## PACKAGE DIMENSION AND PIN LAYOUT

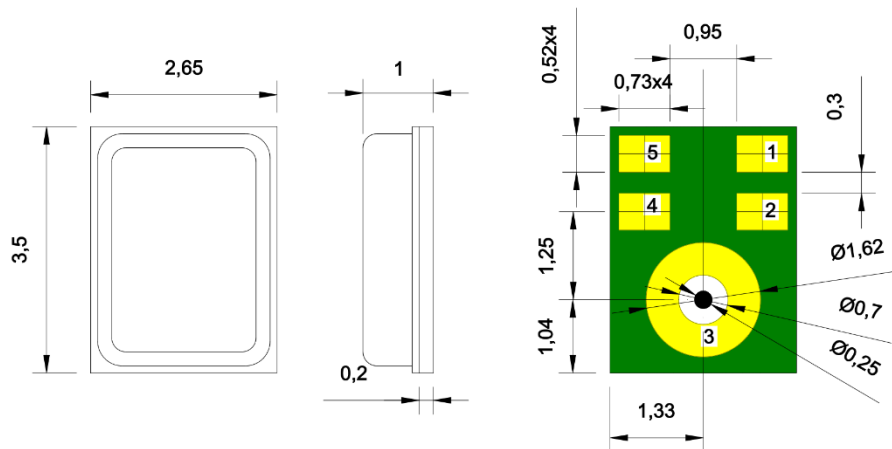

Item	Dimension	Tolerance(+/-)	Units
Length(L)	3.50	0.10	mm
Width(W)	2.65	0.10	mm
Height(H)	1.0	0.10	mm
Acoustic Port(AP)	Ø0.25	0.05	mm

Pin #	Pin Name	Type	Description
1	Output	Signal	Output Signal
2	GND	Ground	Ground
3	GND	Ground	Ground
4	NA	NA	NA
5	VDD	Supply	Power supply

# Analog Bottom Mount MEMS Microphone

## Terminology

1. **POWER:** The Supply Voltage Positive Terminal (Pad name "VDD" in Electrical layout drawing) which is connected to the Microphone Sensing Element.
2. **OUTPUT:** The Output Terminal, where the electrical signal equivalent to the acoustic pressure is available, i.e. the Microphone output. (Pad name "OUTPUT" in Electrical layout drawing)
3. **COMMON:** The Terminal where the supply negative (Pad name "GND" in Electrical layout drawing) is connected to microphone package.
4. **SENSITIVITY:** Sensitivity is the open circuit output voltage amplitude for a given sound pressure at the microphone diaphragm. This is frequency dependent so typically quoted at 1KHz. Units are defined in dB logarithmic scale.
5. **FREQUENCY RESPONSE:** It is the plot of Sensitivity in dB vs frequency [Hz], it depends on transducer mechanism directional response, and reflection from room boundaries – usually quote free-field response.
6. **DIRECTIVITY:** It is the response pattern that expresses the geometric shape of the region of sensitivity surrounding the microphone, omni directional, uni directional, bi- directional.

## FUNCTIONAL BLOCK DIAGRAM

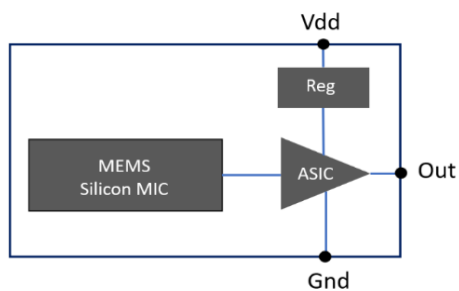

## ELECTRICAL BLOCK DIAGRAM

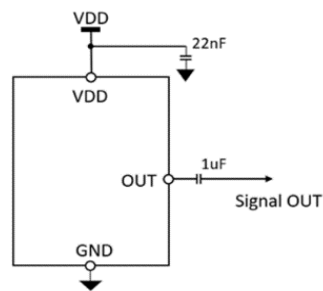

# Analog Bottom Mount MEMS Microphone

## Packaging Information

Tape & Reel Specification

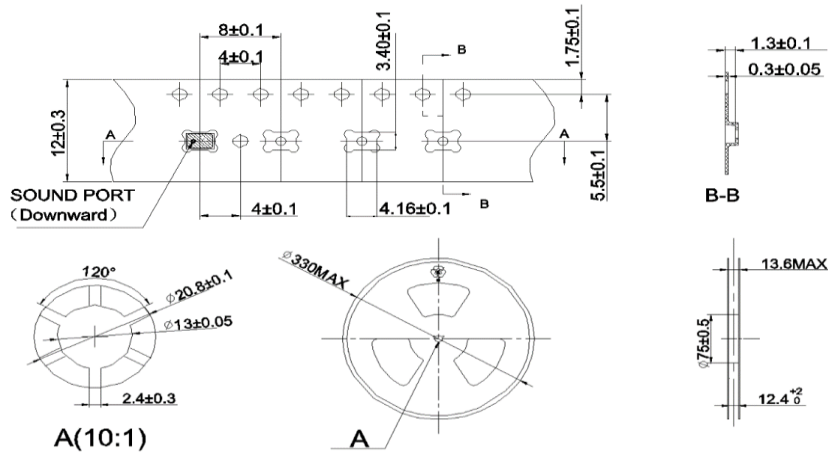

## Packaging Information

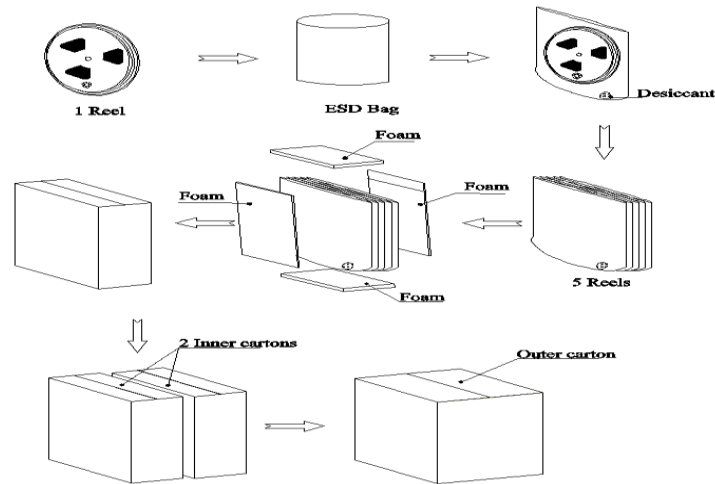

Packaging quantity:

1 Reel=5000pcs

1 Inner Carton =5Reels=25000pcs

1 Outer Carton=2 Inner Cartons=50000pcs

# Analog Bottom Mount MEMS Microphone

## PROCESSING INFORMATION

### Recommended Reflow Process Condition:

Recommend reflow profile, solder reflow  $\leq 260^{\circ}\text{C}$  (for 30s Max of peak temperature).

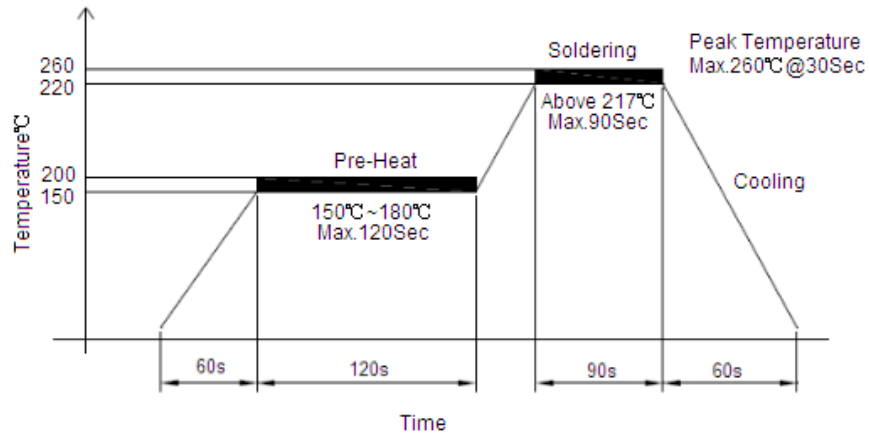

### **Important Notes**

To minimize device damage:

- Do not wash or clean the boards after the reflow process.
- Do not apply airflow with pressure exceeding 0.3MPa to blow into the port hole within a distance of less than 5 cm.
- Do not expose the device to ultrasonic processing or cleaning.
- Do not apply a vacuum over the port hole of the microphone.

### Pickup Tool Pick Location & PCB Solder Pad Layout:

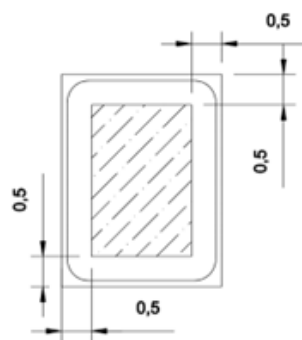

Recommended Pickup Location

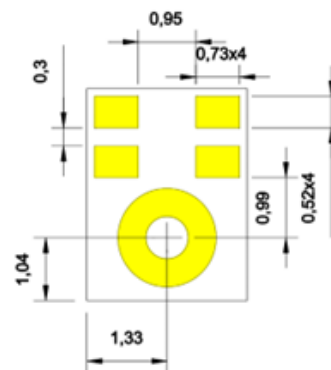

Recommended Solder Pad Layout



# Analog Bottom Mount MEMS Microphone

## TEST SETUP

### Sensitivity Test in Anechoic Room

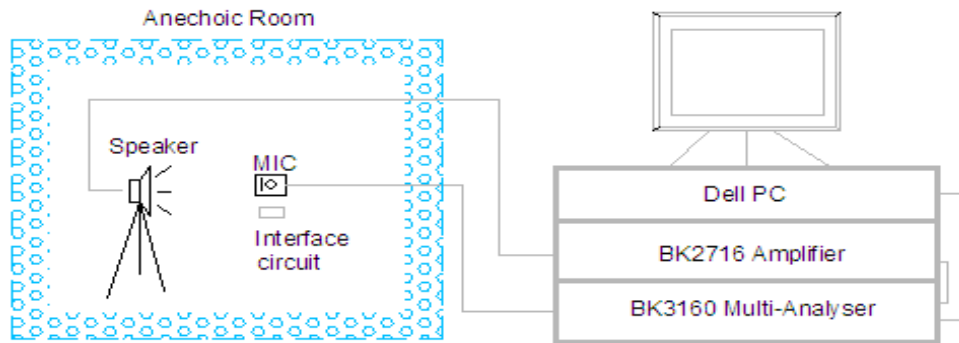

## Measurement Circuit

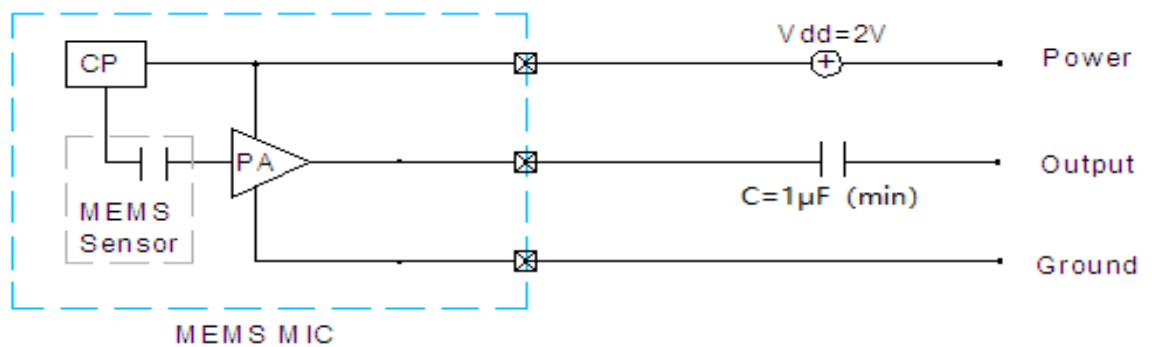

# Analog Bottom Mount MEMS Microphone

## RELIABILITY TEST

The samples should be placed in the room with 23+/-2°C, 55+/-10%R.H. for 2 hours at least before final measurement, unless otherwise specified.

Item	Detail	Standard
Simulated Reflow (Without Solder)	Samples for qualification testing require 3 Times 260±5 °C reflow solder profiles. 2 hours of settling time is required between each reflow profile test.	±3 dB
Static Humidity	Precondition at +25°C for 1 hour. Then expose to +85°C with 85% relative humidity for 1000 hours.	±3 dB
Temperature Shock	Each cycle shall consist of 30 minutes at -40°C, 30 minutes at +125°C with 5 minutes transition time. Test duration is for 30 cycles, starting from cold to hot temperature.	±3 dB
ESD Sensitivity	Perform ESD sensitivity threshold measurements for each contact according to MIL-STD-883G, Method 3015.7 for Human Body Model. Identify the ESD threshold levels indicating passage of 8000V Human Body Model.	±3 dB
Random Vibrations	Vibrate randomly along three perpendicular directions for 30 minutes in each direction, 4cycles from 20Hz~2000Hz with a peak acceleration 20g.	±3 dB
Mechanical Shock	Subject samples to half sine shock pulses (3000g±15% for 0.3ms) in each direction, totally 18 shocks.	±3 dB
Operation Life	Subject samples to +125°C for 168 hours under full maximum rated voltage.	±3 dB
Drop Test	The test was repeated in six directions for three times, Dropped from 1.5m height on to a steel surface, total 18 times and inspected for mechanical damage. Note: Sensitivity should vary within +/-3dB from initial sensitivity after test conditions are performed.	±3 dB

## Delivery Standard:

- Product delivered with 100% testing.
- All parts are tested for sensitivity at 1KHz.
- Product samples tested for frequency curve and SNR.



# Analog Bottom Mount MEMS Microphone

## PRODUCT NAMING CONVENTION

Company name	Packaging size Length (mm) Width (mm)	Output A = Analog D = Digital	Mount T=Top Mount B= Bottom mount	Sensitivity -dB (V/Pa)	Noise dB	Status
IR Sensors & Systems						
IR	3526	A	B	38	68	Active

## DOCUMENT HISTORY

Document Version	Date of Release	Changes
1.0	Feb. 15 <sup>th</sup> , 2024	Initial Version

# Analog Bottom Mount MEMS Microphone

## INTERNATIONAL CONTACT INFORMATION

### SINGAPORE

Anu Austin

Address: 200, Cantonment Road, #05-03/04 Southpoint Singapore-089763

Phone number: +65 96235457

Email address:

[anu.austin@irsensorssystems.com](mailto:anu.austin@irsensorssystems.com)

### INDIA

Memstech

Address: 83 A2, New no: 136 Bharathi Colony, 3rd Street,  
Peelamedu, Coimbatore - 641 004, Tamilnadu, India

Branch office:

5/63 OMR Egattur Chennai - 600130, Tamilnadu, India  
Phone number: +91 84898 13526

Email address:

[guru@memstech.com](mailto:guru@memstech.com)

### EUROPE

Dieter Naegele

Address: Heimesgasse 19d, Ingelheim am Rhein-55218

Phone number: +4915253923397

Email address:

[dieter.naegele@irsensorssystems.com](mailto:dieter.naegele@irsensorssystems.com)

### NORTH AMERICA

K. Sooriakumar

Address: 75 Boniface Drive

Rochester, NY 14620

Phone number: +1 585 7362223

Email address:

[k.soori@irsensorssystems.com](mailto:k.soori@irsensorssystems.com)